

STA-RITE®

DURA-GLAS™ CENTRIFUGAL PUMPS WITH INTEGRAL TRAP

O W N E R ' S M A N U A L

INSTALLATION, OPERATION & PARTS

P2R and P2RA Series MODELS

HP	P2R Series	P2RA Series
1/2	-	P2RA52C3-119
3/4	P2R52D3-124	P2RA52D3-120
1	P2R52E3-125	P2RA52E3-124
1-1/2	P2R52F3-126	P2RA52F3-125
2	P2R52G3-122	P2RA52G3-126
2-1/2	-	P2RAA52G3-122

MEMBER



NATIONAL
SPA & POOL
INSTITUTE

This manual should be furnished to the end user of this pump; its use will reduce service calls and chance of injury and will lengthen pump life.

Sta-Rite Pool/Spa Group

293 Wright Street, Delavan, WI 53115

North America: 800-752-0183, FAX 800-582-2217

International: 414-728-5551, FAX: 414-728-4461, TELEX: ITT 4970245

Oxnard, CA • Union City, TN • Delavan, WI • Mississauga, Ont.

‘P2R’ and ‘P2RA’ SERIES PUMP WITH TRAP

To avoid unneeded service calls, prevent possible injuries, and get the most out of your pump, READ THIS MANUAL CAREFULLY!

The Sta-Rite ‘P2R’ and ‘P2RA’ Series Self-priming Centrifugal pump:

- Is designed for use with swimming pools or as a centrifugal pump.
- Is an excellent performer; durable, reliable.

Table of Contents

Safety Instructions	3
Installation.....	4-5
Electrical.....	6
Operation	7
Storage/Winterizing	7-8
Pump Service	9-10
Troubleshooting Guide	11
Repair Parts List	12
Warranty.....	15

IMPORTANT SAFETY INSTRUCTIONS

Always follow basic safety precautions with this equipment, including the following.

⚠ WARNING To reduce the risk of injury, do not permit children to use this product unless they are closely supervised at all times.

⚠ CAUTION This pump is for use with permanently installed pools and may also be used with hot tubs and spas if so marked. Do not use with storable pools. A permanently installed pool is constructed in or on the ground or in a building such that it cannot be readily disassembled for storage. A storable pool is constructed so that it may be readily disassembled for storage and reassembled to its original integrity.

SAVE THESE INSTRUCTIONS

READ AND FOLLOW SAFETY INSTRUCTIONS!

⚠ This is the safety alert symbol. When you see this symbol on your system or in this manual, look for one of the following signal words and be alert to the potential for personal injury.

⚠ DANGER warns about hazards that **will** cause death, serious personal injury, or major property damage if ignored.

⚠ WARNING warns about hazards that **can** cause death, serious personal injury, or major property damage if ignored.

⚠ CAUTION warns about hazards that **will** or **can** cause minor personal injury or property damage if ignored.

NOTICE indicates special instructions not related to hazards.

Carefully read and follow all safety instructions in this manual and on equipment. Keep safety labels in good condition; replace if missing or damaged.

⚠ WARNING **Incorrectly installed or tested equipment may fail, causing severe injury or property damage.**
Hazardous pressure Read and follow instructions in owner's manual when installing and operating equipment. Have a trained pool professional perform all pressure tests.

1. Do not connect system to a high pressure or city water system.
2. Use equipment only in a pool or spa installation.
3. Trapped air in system can cause explosion. BE SURE all air is out of system before operating or testing equipment.

Before pressure testing, make the following safety checks:

Check all clamps, bolts, lids, and system accessories before testing.

Release all air in system before testing.

Tighten Sta-Rite trap lids to 30 ft. lbs. (4.1 kg-m) torque for testing.

Water pressure for test must be less than 25 PSI (7.5 kg/cm²).

Water Temperature for test must be less than 100° F. (38° C).

Limit test to 24 hours. After test, visually check system to be sure it is ready for operation. Remove trap lid and retighten hand tight only.

NOTICE: These parameters apply to Sta-Rite equipment only. For non-Sta-Rite equipment, consult manufacturer.

⚠ CAUTION Motor normally operates at high temperature and will be too hot to touch. It is protected from heat damage during operation by an automatic internal cutoff switch. Before handling pump or motor, stop motor and allow it to cool for 20 minutes.

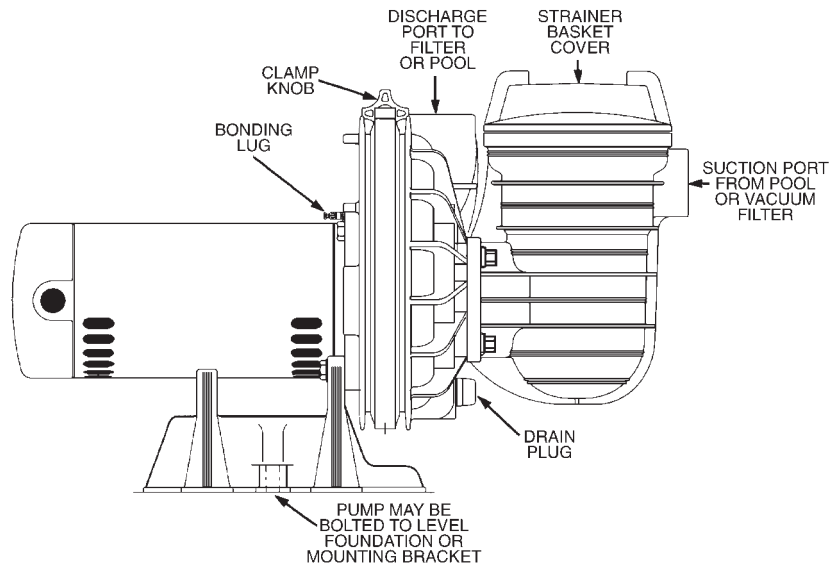

FIGURE 1

INSTALLATION

Only qualified, licensed personnel should install pump and wiring.

Pump mount must:

Be solid - Level - Rigid - Vibration free. (To reduce vibration and pipe stress, bolt pump to mount.)

Allow pump suction inlet height to be as close to water level as possible.

Allow use of short, direct suction pipe (To reduce friction losses).

Allow for gate valves in suction and discharge piping.

Have adequate floor drainage to prevent flooding.

Be protected from excess moisture.

Allow adequate access for servicing pump and piping.

NOTICE: Use Teflon tape or Plasto-Joint Stik¹ for making all threaded connections to the pump. Do not use pipe dope; pipe dope will cause stress cracking in the pump.

NOTICE: Pump suction and discharge connections have molded in thread stops. DO NOT try to screw pipe in beyond these stops.

Teflon Taping Instructions:

Use only new or clean PVC pipe fittings.

Wrap male pipe threads with one to two layers of Teflon tape. Cover entire threaded portion of pipe.

Do not overtighten or tighten past thread stop in pump port!

If leaks occur, remove pipe, clean off old tape, rewrap with one to two additional layers of tape and remake the connection.

NOTICE: Support all piping connected with pump!

¹Lake Chemical Co., Chicago, Illinois

Piping:

Use at least 1-1/2" IPS PVC pipe with 5" trap. Use at least 2" pipe with 6" trap. Increase size if a long run is needed.

To avoid strains on the pump, support both suction and discharge pipes independently. Place these supports near the pump.

To avoid a strain left by a gap at the last connection, start all piping at the pump and run pipe **away** from the pump.

Never use a suction pipe smaller than pump suction connection.

To avoid airlocking, slope suction pipe slightly upward toward the pump.

NOTICE: To prevent flooding when removing pump for service, all flooded suction systems **must** have gate valves in suction and discharge pipes.

Fittings:

Fittings restrict flow; for best efficiency use fewest possible fittings.

Avoid fittings which could cause an air trap.

Pool fittings must conform to International Association of Plumbing and Mechanical Officials (IAPMO) standards.

Use only non-entrapping suction fitting or double suction.

TABLE I - RECOMMENDED FUSING AND WIRING DATA

P2RA Series

Motor H.P.	Branch Fuse Rating Amps*	Max Load Amps	Voltage/ Hz/Phase	Dist. in Ft. (m) (Serv. to Motor)			Wire Size AWG (mm)
				0-100' (0-30)	101-200' (31-60)	201-300' (61-90)	
1/2	15	2.4	200/60/3	14 (2)	14 (2)	14 (2)	}
3/4	15	3.3	200/60/3	14 (2)	14 (2)	14 (2)	
1	15	3.8	200/60/3	14 (2)	14 (2)	14 (2)	
1-1/2	15	5.6	200/60/3	14 (2)	14 (2)	14 (2)	
2	15	6.2	200/60/3	14 (2)	14 (2)	14 (2)	
2-1/2	20	7.7	200/60/3	14 (2)	14 (2)	14 (2)	

*Time delay fuses are recommended instead of standard fuses in any motor circuit.

P2R Series

Motor H.P.	Branch Fuse Rating Amps*	Max Load Amps	Voltage/ Hz/Phase	Dist. in Ft. (m) (Serv. to Motor)			Wire Size AWG (mm)
				0-100' (0-30)	101-200' (31-60)	201-300' (61-90)	
3/4	15	3.8	200/60/3	14 (2)	14 (2)	14 (2)	}
1	15	5.6	200/60/3	14 (2)	14 (2)	14 (2)	
1-1/2	15	6.6	200/60/3	14 (2)	14 (2)	14 (2)	
2	15	8.0	200/60/3	14 (2)	14 (2)	14 (2)	

*Time delay fuses are recommended instead of standard fuses in any motor circuit.

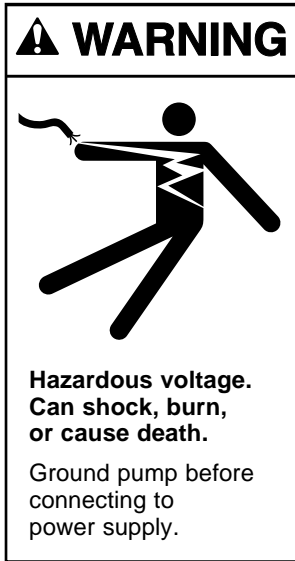

ELECTRICAL

- ⚠ Ground motor before connecting to electrical power supply. Failure to ground motor can cause severe or fatal electrical shock hazard.
- ⚠ Do not ground to a gas supply line.
- ⚠ To avoid dangerous or fatal electrical shock, turn OFF power to motor before working on electrical connections.
- ⚠ Ground Fault Circuit Interrupter (GFCI) tripping indicates an electrical problem. If GFCI trips and will not reset, have a qualified electrician inspect and repair electrical system.
- ⚠ Exactly match supply voltage to nameplate voltage! Incorrect voltage can cause fire or seriously damage motor and voids warranty. If in doubt consult a licensed electrician.

Voltage:

Voltage at motor must be not more than 10% above or below motor nameplate rated voltage or motor may overheat, causing overload tripping and reduced component life. If voltage is less than 90% or more than 110% of rated voltage when motor is running at full load, consult power company.

Grounding/Bonding:

Install, ground, bond and wire motor according to local or National Electrical Code requirements.

Permanently ground motor. Use green ground terminal provided under motor canopy or access plate (See Figure 2); use size and type wire required by code. Connect motor ground terminal to electrical service ground.

Bond motor to pool structure. Use a solid copper conductor, size No. 8 AWG or larger. Run wire from external bonding lug (see Figure 2) to reinforcing rod or mesh.

Wiring:

Pump must be permanently connected to circuit. Table I, Page 5, gives correct wire and circuit breaker sizes for the pump alone. If other lights or appliances are also on the same circuit, be sure to add their amp loads to pump amp load before figuring wire and circuit breaker sizes. (If unsure how to do this or if this is confusing, consult a licensed electrician.) Use the load circuit breaker as the master on-off switch.

Install a Ground Fault Circuit Interrupter (GFCI) in circuit; it will sense a short-circuit to ground and disconnect power before it becomes dangerous to pool users. For size of GFCI required and test procedures for GFCI, see manufacturer's instruction.

In case of power outage, check GFCI for tripping (which will prevent normal pump operation). Reset if necessary.

NOTICE: If you do not use conduit when wiring motor, **be sure** to seal wire opening on end of motor to prevent dirt, bugs, etc., from entering.

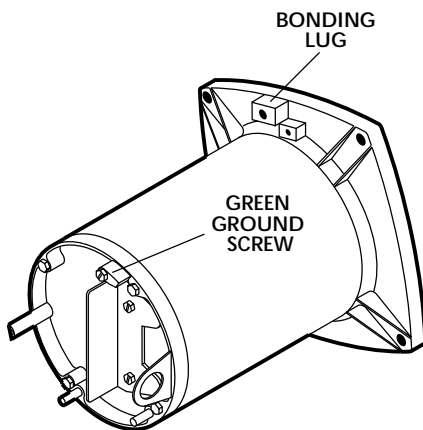

FIGURE 2: Typical ground screw and bonding lug locations



OPERATION

⚠ NEVER run pump dry! Running pump dry may damage seals, causing leakage and flooding! Fill pump with water before starting motor.

⚠ Before removing trap cover:

1. STOP PUMP before proceeding.
2. CLOSE GATE VALVES in suction and discharge pipes.
3. RELEASE ALL PRESSURE from pump and piping system.
4. NEVER tighten or loosen clamp while pump is operating!

⚠ If pump is being pressure tested, be sure pressure has been released before removing trap cover!

⚠ Do not block pump suction! To do so with body may cause severe or fatal injury. Small children using pool must ALWAYS have close adult supervision!

Priming Pump:

Release all air from filter and piping system: see filter owner's manual.

In a flooded suction system (water source higher than pump), pump will prime itself when suction and discharge valves are opened.

If pump is not in a flooded suction system, unscrew and remove trap cover; fill trap and pump with water.

NOTICE: Lubricate trap cover O-Ring with petroleum jelly each time it is removed.

Clean and inspect O-Ring; reinstall on trap cover.

Replace trap cover on trap; turn clockwise to tighten cover.

NOTICE: Tighten trap cover by hand only (no wrenches)! Use a wrench only if necessary to remove lid!

Pump should prime now. Priming time will depend on vertical length of suction lift and horizontal length of suction piping.

If pump does not prime, make sure that all valves are open, suction pipe end is under water, and that there are no leaks in suction pipe. See Troubleshooting Guide, Page 10.

Storage/Winterizing:

⚠ WARNING Explosion hazard. Purging the system with compressed air can cause components to explode, with risk of severe injury or death to anyone nearby. Use only a low pressure (below 5 PSI), high volume blower when purging the pump, filter, or piping.

NOTICE: Allowing pump to freeze will damage pump and void warranty!

NOTICE: Do not use anti-freeze solutions (except propylene glycol) in your pool/spa system. Propylene glycol is non-toxic and will not damage plastic system components; other anti-freezes are highly toxic and may damage plastic components in the system.

Drain all water from pump and piping when expecting freezing temperatures or when storing pump for a long time (see instructions, Page 8).

Keep motor dry and covered during storage.

To avoid condensation/corrosion problems, do not cover pump with plastic.

For outdoor/unprotected installations:

1. Enclose entire system in a weatherproof enclosure.
2. To avoid condensation/corrosion damage, allow ventilation; do not wrap system in plastic.
3. Use a 40% propylene glycol/60% water solution to protect pump to -50°F.

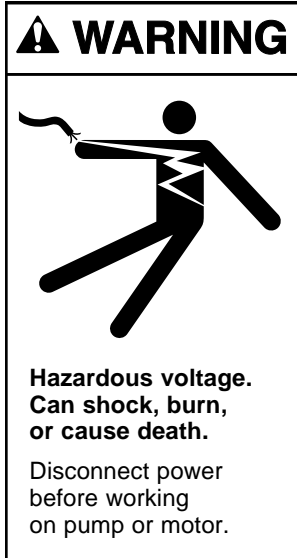

Draining Pump:

1. Pump down water level below all inlets to the pool.
2. Gravity drain system as far as possible.
3. Remove trap cover and use low pressure (5 PSI or less) air to blow accumulated water from the piping system. Use a Sta-Rite U79-11 Lid Wrench to remove trap covers that have been overtightened or have taken a set and cannot be removed by hand.
4. Protect areas which retain water with non-toxic propylene glycol antifreeze ("RV antifreeze").
5. Cap inlet piping after draining to keep water out of the pipes.
6. To prevent pump from freezing, remove trap cover and drain the tank body through the drain plug (Key No. 18, Page 11). Clean pump thoroughly; replace trap cover.
NOTICE: Tighten trap cover by hand only (**no wrenches**)! Use a wrench only if necessary to remove cover!
7. Be sure motor is kept dry and covered.

Startup For Winterized Equipment:

1. Remove any temporary weather protection placed around system for shutdown.
2. Follow filter manufacturer's instructions for reactivation of the filter.
3. Inspect all electrical wiring for damage or deterioration over the shutdown period. Have a qualified serviceman repair wiring as needed.
4. Inspect and tighten all watertight connections.
5. Open all valves in suction and return piping.
6. Remove any winterizing plugs in piping system.
7. Drain all antifreeze from system.
8. Close all drain valves and replace all drain plugs in piping system.
9. Prime pump according to instructions on Page 7.

PUMP SERVICE

Pump should only be serviced by qualified personnel.

Be sure to prime pump (Page 7) before starting.

⚠ Before removing trap cover:

1. **STOP PUMP** before proceeding.
2. **CLOSE GATE VALVES** in suction and discharge pipes.
3. **RELEASE ALL PRESSURE** from pump and piping system.
4. **NEVER** tighten or loosen clamp while pump is operating!

⚠ To avoid dangerous or fatal electrical shock hazard, turn OFF power to motor before working on pump or motor.

Aside from lubricating trap cover O-Ring, no lubrication or regular maintenance is needed beyond reasonable care and periodic cleaning. If shaft seal is worn or damaged, repair as follows:

Pump Disassembly/Removing Old Seal:

⚠ Disconnect power to pump motor.

Be sure gate valves on suction and return piping are closed before starting work.

Release all pressure by opening all vents before starting work.

1. Drain pump by removing drain plugs on bottom of pump body and trap body.

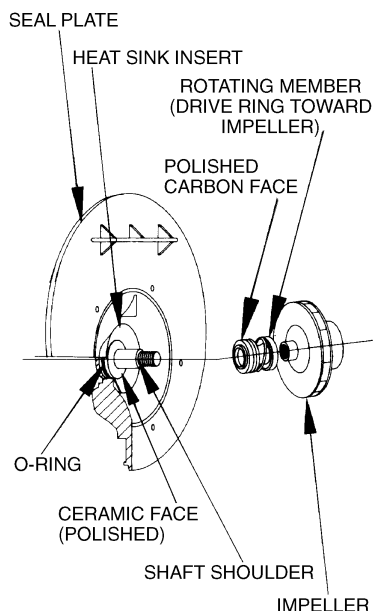

FIGURE 3



FIGURE 4



FIGURE 5

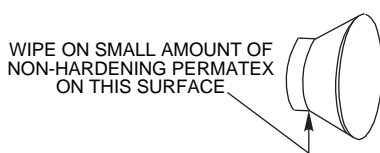

FIGURE 6

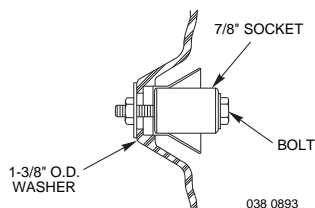

FIGURE 7

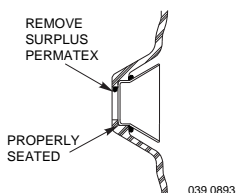

FIGURE 8

2. **Be sure** there is no pressure in trap body; remove cover (unscrew by turning counterclockwise).
3. Remove clamp holding pump halves together.
4. Remove pump base mounting bolts, if used. Motor and seal plate assembly can now be pulled away from pump body.
5. Remove five screws and washers holding diffuser to seal plate. Remove diffuser.
6. Remove motor canopy. Being careful not to touch capacitor terminals, loosen capacitor clamp and move capacitor to one side.
7. Hold shaft with 7/16" open-end wrench on motor shaft flats.
8. Unscrew impeller from shaft (turn counterclockwise when facing it).
9. Remove four screws holding seal plate to motor.
10. Place seal plate face down on flat surface and tap out ceramic seat (Figure 4).
NOTICE: Do not force out heat sink insert (Key No, 7, Page 11). If insert has moved, pump will leak; see "Installing Insert", below.)
11. Clean seal cavity in seal plate and clean motor shaft.

Pump Reassembly/Installing New Seal:

1. Ceramic seat must be clean and free of dirt, grease, dust, etc. Wet outer edge of O-Ring with small amount of liquid detergent; press ceramic seat into seal plate cavity firmly and squarely with finger pressure (Figure 5).
2. If ceramic seat will not locate properly, remove it, place **face up** on bench and reclean cavity. Ceramic seat should now locate.
3. If seat still will not locate properly, place a cardboard washer over the polished face and use a piece of 3/4" standard pipe for pressing purposes. **NOTICE: Be sure** not to scratch or mar polished surface or seal will leak.
4. Remount seal plate to motor. Tighten bolts to 60-80 inch-lbs. (69-92 cm/kg) torque.
5. Apply a **small** amount of liquid detergent to inside diameter of rotating half of seal.
6. Slide rotating seal member, polished face first, over threaded shaft end and shaft shoulder until rubber drive ring hits shaft shoulder. (Figure 3).
NOTICE: Be sure not to nick or scratch polished seal face; seal will leak if face is damaged.
7. Screw impeller onto shaft (clockwise); this will automatically locate seal in seal plate.
8. Mount diffuser on seal plate; tighten screws to 10-14 inch-lbs. (11.5-16 cm/kg) torque.
9. Assemble motor and seal plate to volute; be sure clamp is properly seated. **NOTICE: Clamp knob** can be located in any position around volute; if it is moved after assembly, tighten knob while tapping around clamp to assist sealing. Do not move clamp while pump is full of water.
10. Reinstall pump base mounting bolts (if used) and prime pump according to instructions on Page 7.

Installing Heat Sink Insert:

If the heat sink insert moves or shifts during seal removal, remove and reinstall it to prevent leakage.

1. To remove heat sink insert, grasp with fingers at the large end and move back and forth. Do not deform.
2. Replace heat sink insert as follows:
 - A. Clean off old sealant and foreign material; clean out insert cavity.
 - B. Apply a small amount of non-hardening silicone RTV on surface of insert (see Figure 6).
 - C. Pull insert into cavity (see Figure 7).
 - D. Remove surplus silicone RTV from insert cavity (see Figure 8).



TROUBLESHOOTING GUIDE

- ⚠ Read and understand safety and operating instructions in this manual before doing any work on pump!
- ⚠ Only qualified personnel should electrically test pump motor!

FAILURE TO PUMP; REDUCED CAPACITY OR DISCHARGE PRESSURE

Suction leaks/lost prime:

1. Pump must be primed; make sure that pump volute and trap are full of water. See priming instructions, Page 7.
2. Make sure there are no leaks in suction piping.
3. Make sure suction pipe inlet is well below the water level to prevent pump from sucking air.
4. If suction trap gasket is defective, replace it.
5. Suction lift of 15 to 25 feet will reduce performance. Suction lift of more than 25 feet will prevent pumping and cause pump to lose prime. In either case, move pump closer (vertically) to water source. Make sure suction pipe is large enough.

Clogged pipe/trap/impeller, worn impeller:

6. Make sure suction trap is not clogged; if it is, clean trap and strainer.
7. Make sure impeller is not clogged (follow steps 1 through 7 under "Removing Old Seal", Page 8; check impeller for clogging; follow steps 7 through 11 under "Installing New Seal", Page 9, for reassembly).
8. Impeller and diffuser may be worn. If so, order replacement parts from Repair Parts List, Page 11.
9. Pump may be trying to push too high a column of water. If so, a "higher head" pump is needed.

Electrical:

10. Pump may be running too slowly; check voltage at motor terminals and at meter while pump is running. If low, see wiring instructions or consult power company. Check for loose connections.
11. Pump may be too hot.
 - A. Check line voltage; if less than 90% or more than 110% of rated voltage consult a licensed electrician.
 - B. Increase ventilation.
 - C. Reduce ambient temperature.
 - D. Tighten any loose connections.

Mechanical Troubles and Noise:

1. If suction and discharge piping are not adequately supported, pump assembly will be strained. See "Installation", Page 4.
2. Do not mount pump on a wooden platform! Securely mount on concrete platform for quietest performance.

REPAIR PARTS LIST
P2R SERIES
DURA-GLAS® POOL PUMP
3/4 through 2 H.P. Models

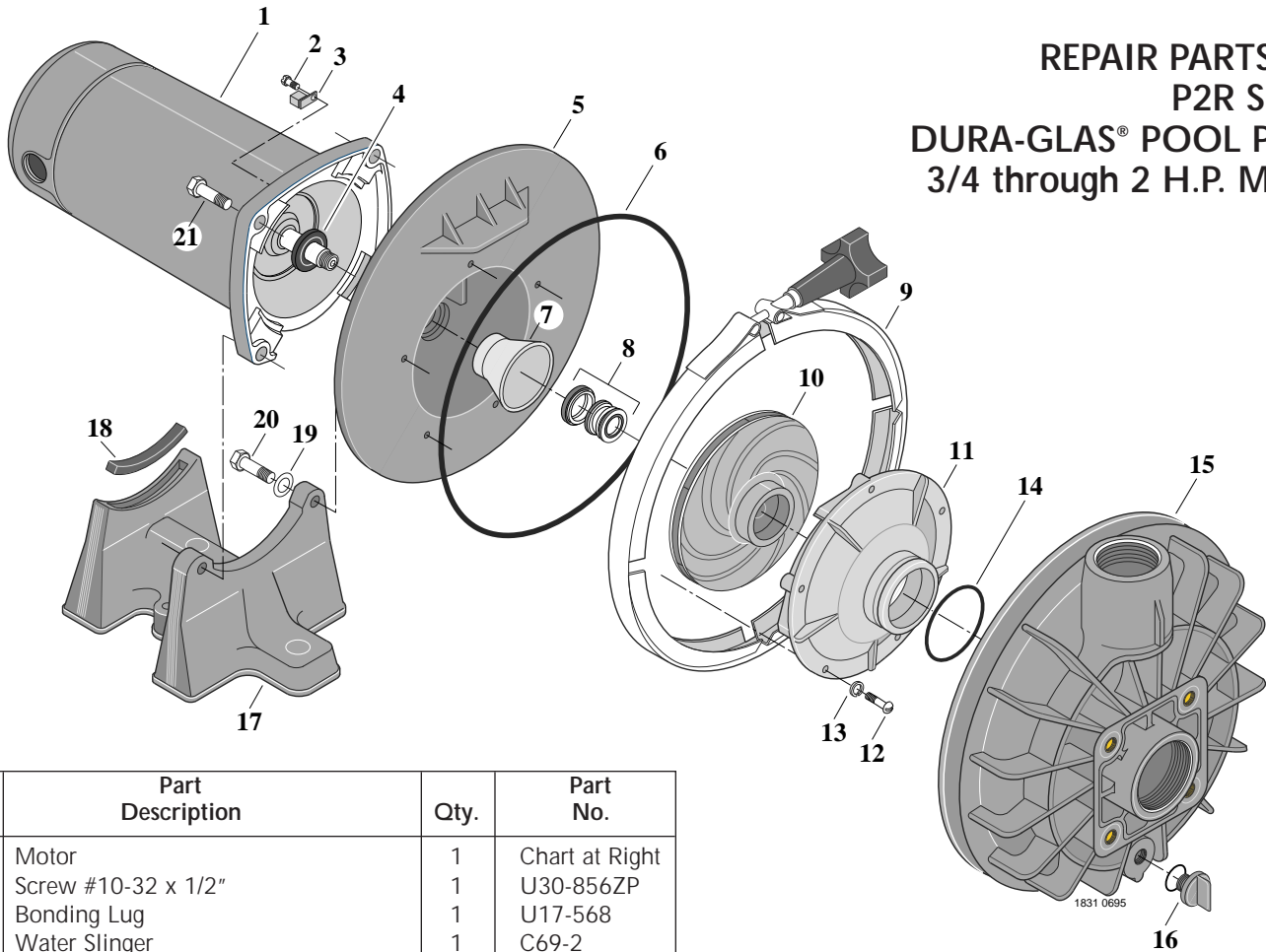

Key No.	Part Description	Qty.	Part No.
1	Motor	1	Chart at Right
2	Screw #10-32 x 1/2"	1	U30-856ZP
3	Bonding Lug	1	U17-568
4	Water Slinger	1	C69-2
5	Seal Plate	1	C203-137P1
6	O-Ring	1	U9-228A
7	Insert	1	J3-2
8	Shaft Seal	1	U109-93SS
9	Clamp	1	C19-37A
	• Clamp Knob	1	WC36-22
10	Impeller	1	Chart at Right
	• Impeller Screw	1	C30-12
11	Diffuser	1	C1-200PA
12	Screw #8-32 x 7/8"	5	U30-542SS
13	Washer, #8 Lock	5	U43-21SS
14	Diffuser O-Ring	1	U9-226
15	Pump Body	1	C176-47P1
16	Drain Plug 1/4" NPT	1	U178-920P
17	Base w/Motor Pad	1	C104-42P
18	Motor Pad	1	C35-11
19	Washer, Flat	2	U43-42SS
20	Screw 3/8-16 x 1-3/4" Hex Head	2	U30-77SS
21	Screw 3/8-16 x 1" Hex Head	2	U30-74SS
	• Reducer 2" x 1-1/2"	1	C78-7P
	• Tag, "CAUTION This pump equipped with mechanical shaft seal. . ."		61002-0002
	• Decal, "Overtight. . ."		U27-644
	• Tag, "IMPORTANT/WARNING/CAUTION. . ."		C63-12
	• Tag, "CAUTION. . ."		C63-11
	• Model Plate		U33-104B

Parts are common to all models listed except as noted:
 Key Nos. 1, Motor; and 10, Impeller are listed below.

Model No.	HP	Motor No. Key No. 1	Impeller No. Key No. 10
200 Volt			
P2R52D3-124	3/4	AP100DH2	C105-138PEBA
P2R52E3-125	1	AP100EH2	C105-137PEBA
P2R52F3-126	1-1/2	AP100FH2	C105-137PDBA
P2R52G3-122	2	AP100GH2	C105-137PDA

P2R5 models include 5" trap, Pkg. 115.
 P2RX models do not include trap.
 For trap parts, see Page 13.
 For Parts-Pak parts, see Page 13.

• Not illustrated.

REPAIR PARTS LIST
P2RA SERIES
DURA-GLAS® POOL PUMP
1/2 through 2-1/2 H.P. Models

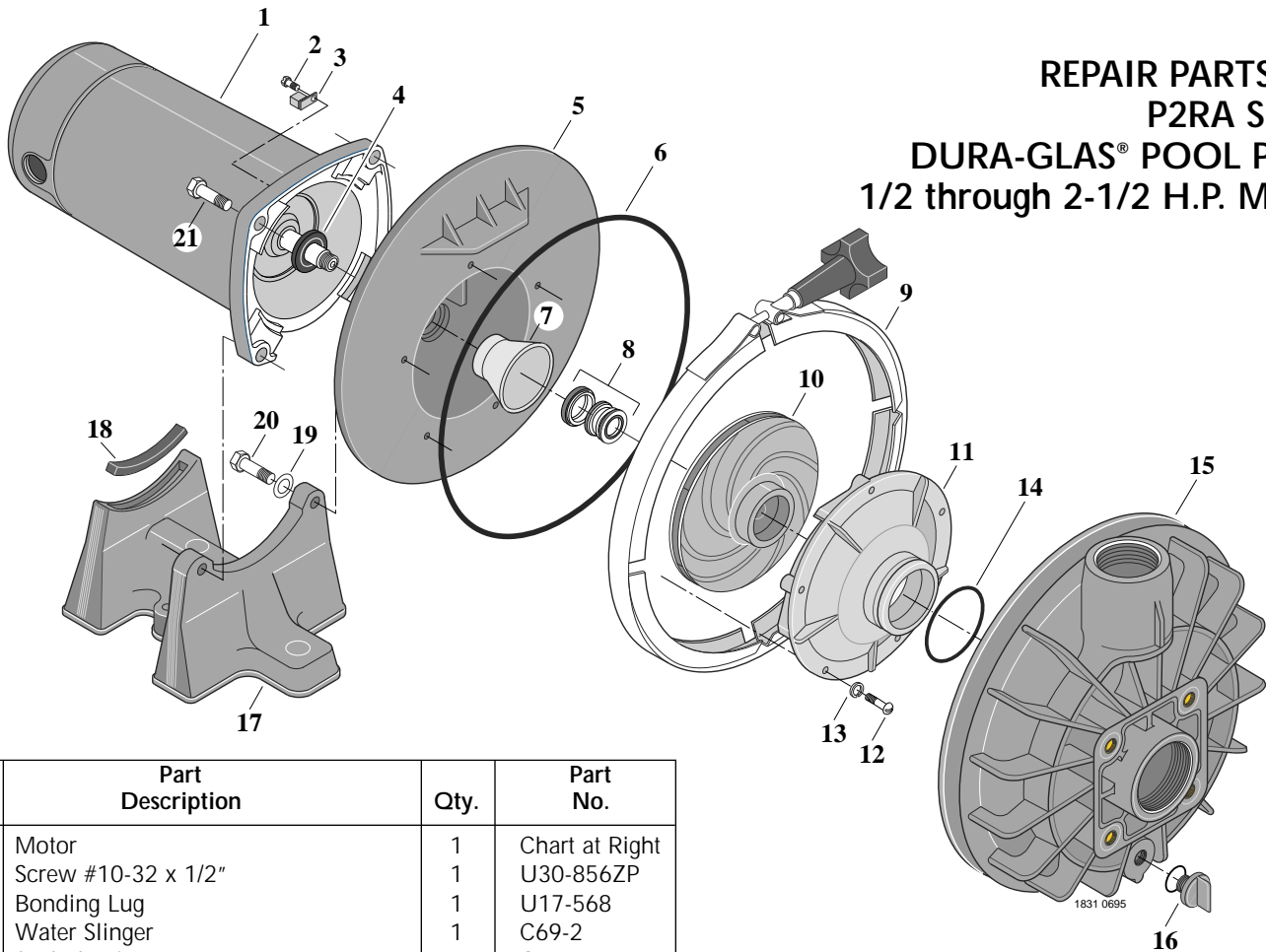

Key No.	Part Description	Qty.	Part No.
1	Motor	1	Chart at Right
2	Screw #10-32 x 1/2"	1	U30-856ZP
3	Bonding Lug	1	U17-568
4	Water Slinger	1	C69-2
5	Seal Plate*	1	C203-137P1
6	O-Ring	1	U9-228A
7	Insert	1	J3-2
8	Shaft Seal	1	U109-93SS
9	Clamp	1	C19-37A
	• Clamp Knob	1	WC36-22
10	Impeller	1	Chart at Right
	• Impeller Screw	1	C30-12
11	Diffuser**	1	C1-200PA
12	Screw #8-32 x 7/8"	5	U30-542SS
13	Washer, #8 Lock	5	U43-21SS
14	Diffuser O-Ring	1	U9-226
15	Pump Body	1	C176-47P1
16	Drain Plug 1/4" NPT	1	U178-920P
17	Base w/Motor Pad	1	C104-42P
18	Motor Pad	1	C35-11
19	Washer, Flat	2	U43-42SS
20	Screw 3/8-16 x 1-3/4" Hex Head	2	U30-77SS
21	Screw 3/8-16 x 1" Hex Head	2	U30-74SS
	• Reducer 2" x 1-1/2"	1	C78-7P
	• Tag, "CAUTION This pump equipped with mechanical shaft seal. . ."		61002-0002
	• Decal, "Overtight. . ."		U27-644
	• Tag, "IMPORTANT/WARNING/ CAUTION. . ."		C63-12
	• Tag, "CAUTION. . ."		C63-11
	• Model Plate		U33-104B

Parts are common to all models listed except as noted:
 Key Nos. 1, Motor; and 10, Impeller are listed below.

Model No.	HP	Motor No. Key No. 1	Impeller No. Key No. 10
200 Volt			
P2RA52C3-119	1/2	AP100CH2	C105-92PRA
P2RA52D3-120	3/4	AP100DL2	C105-92PSA
P2RA52E3-124	1	AP100EL2	C105-138PEBA
P2RA52F3-125	1-1/2	AP100FL2	C105-137PDBA
P2RA52G3-126	2	AP100GL2	C105-137PDBA
P2RAA52G3-122	2-1/2	AP100G5L2	C105-137PDA

P2R5 models include 5" trap, Pkg. 115.
 P2RX models do not include trap.
 For trap parts, see Page 13.
 For Parts-Pak parts, see Page 13.

* Model P2RAA52G3-122 uses Part No. C203-137P.
 ** Model P2RA52C3 uses Part No. C1-217P; P2RA52D3 uses Part No. C1-216P.
 • Not illustrated.

5" TRAP/ADAPTER ASSEMBLY PKG. 115

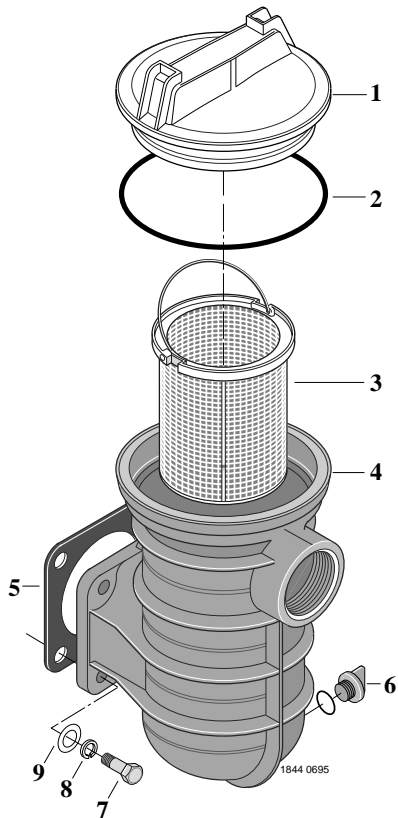

REPAIR PARTS LIST - 5" and 6" TRAPS*

Part No. Key No.	Part Description	Pkg. 115 5" Trap	Pkg. 161 6" Trap
1	Trap Cover	C3-139P1	16920-0011
2	O-Ring - Cover	U9-229	16920-0012
3	Strainer Basket	C108-33P	16920-0017
4	Trap Body	C153-53P1	C153-58P
5	Gasket	C20-123	C20-123
6	Pipe Plug - 1/4" NPT (w/O-Ring)	U178-920P	U178-920P
7	Capscrew-5/16-18x1-1/4"	U30-64SS(4)	U30-64SS(4)
8	Washer, Lock 5/16"	U43-11SS(4)	U43-11SS(4)
9	Washer, Flat 5/16"	U43-41SS(4)	U43-41SS(4)

*Quantity one unless otherwise indicated ().

Overhaul Kits

H.P.	Parts-Pak Number	
	P2R	P2RA
1/2	PP1011	PP1010
3/4	PP1014	PP1011
1	PP1016	PP1014
1-1/2	PP1018	PP1016
2	-	PP1018

Kit includes: Impeller, Diffuser, Shaft Seal, Gaskets, O-Rings, Hardware, Shims, Wear Rings and Inserts.

Seal/Gasket Kit

Kit includes Shaft Seal, Gaskets, and O-Rings. For all horsepower P2R and P2RA series pumps. Parts-Pak No. PP1000.

Trap Cover/O-Ring Kit (5" trap)

Kit includes C3-139P1 Trap Cover and U9-229 O-Ring. For all horsepower P2R and P2RA series pumps. Parts-Pak No. PP2075.

Trap Basket/O-Ring Kit (5" trap)

Kit includes C108-33P Strainer Basket and U9-229 O-Ring. For all horsepower P2R and P2RA series pumps. Parts-Pak No. PP2062.

6" TRAP/ADAPTER ASSEMBLY PKG. 161

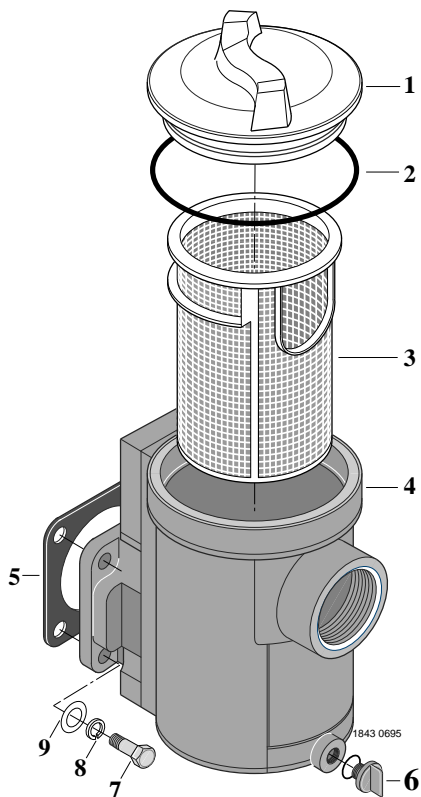

STA-RITE LIMITED WARRANTY

Pumps, filters, skimmers, underwater lights (except bulbs), accessories and fittings manufactured by Sta-Rite are warranted to be free of defects in material and workmanship for one (1) year from date of installation.

Product specific warranties:

Year from date of installation

<i>HRPB, DEPB and System 3 – Tanks</i>	10 years
Internal filter components and valves	1 year
<i>Automatic Pool Cleaners including Hose</i>	2 years
<i>Cristal-Flo filters – Tanks</i>	10 years pro-rated*
Valve and internal components.	1 year
<i>Posi-Flo II – Tanks</i>	10 years
Elements	1 year
<i>Waterford Sand – Tanks</i>	10 years pro-rated*
Pumps	1 year
Valve and Internals	1 year
<i>Waterford Cartridge – Filter Tank</i>	10 years
Pumps	1 year
<i>System 3 Above Ground Systems – Tanks</i>	10 years
Pumps	1 year
Platform and Internals	1 year
<i>Pumps</i>	1 year
When equipped with A.O. Smith 2-compartment motors (Does not include pumps sold as part of a systems package)	2 years

The foregoing warranties relate to the original consumer purchaser ("Purchaser") only. Sta-Rite shall have the option to repair or replace the defective product, at its sole discre-

tion. Purchasers must pay all labor and shipping charges necessary to replace the product covered by this warranty. Requests for warranty service must be made through the installing dealer. This warranty shall not apply to any product that has been subject to negligence, misapplication, improper installation or maintenance, or other circumstances which are not in Sta-Rite's direct control.

* Full warranty coverage is in effect for one year after installation. The pro-rated warranty covers the *tank only* during the 2nd through 10th year after installation. The amount covered decreases by 10% each year. (ie., 2nd year 90% covered, 3rd year 80% covered, etc.).

This warranty sets forth Sta-Rite's sole obligation and Purchaser's exclusive remedy for defective products.

STA-RITE SHALL NOT BE LIABLE FOR ANY CONSEQUENTIAL, INCIDENTAL OR CONTINGENT DAMAGES WHATSOEVER.

THE FOREGOING WARRANTIES ARE EXCLUSIVE AND IN LIEU OF ALL OTHER EXPRESS WARRANTIES. IMPLIED WARRANTIES, INCLUDING BUT NOT LIMITED TO THE IMPLIED WARRANTIES OF MERCHANTABILITY AND FITNESS FOR A PARTICULAR PURPOSE, SHALL NOT EXTEND BEYOND THE DURATION OF THE APPLICABLE EXPRESS WARRANTIES PROVIDED HEREIN.

Some states do not allow the exclusion or limitation of incidental or consequential damages or limitations on how long an implied warranty lasts, so the above limitations or exclusion may not apply to you. This warranty gives you specific legal rights and you may also have other rights which vary from state to state.

Supersedes all previous publications.

Sta-Rite Industries, Inc.
293 Wright Street
Delavan, WI 53115

▲ Retain Warranty Certificate (upper portion) in a safe and convenient location for your records.

DETACH HERE: Fill out bottom portion completely and mail within 10 days of purchase/installation to:

▼ Sta-Rite, Attn: Warranty Dept., 293 Wright St., Delavan, WI 53115

STA-RITE®



Warranty Registration Card

Name _____

Address _____

City _____ State _____ Zip _____

Purchase Date _____

Product Purchased _____

New installation Replacement

Type of Pool Inground Vinyl Fiberglass Gunite

Size of Pool _____

Years pool has been in service less than 1 1-3 3-5 5-10

Purchased from:
 Company name _____

Address _____

City _____ State _____ Zip _____

Please send me more information on these other products from Sta-Rite.

- Pumps Filters Automatic Pool Cleaners
- Maintenance Equipment Test Strips